

MÈCHE À FAÇONNER AU CARBURE À FOND PLAT

• TCT FORSTNER BITS

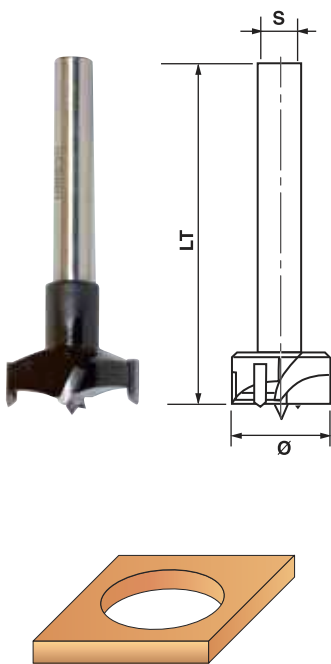

Pointe de centrage, 2 coupes dégageuses, 2 traçoirs.
Rotation à droite uniquement.

With central point and 2 spurs, clockwise only.

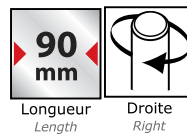
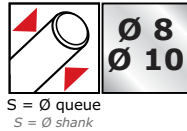

Ø	LT	S	Code droite	Prix HT €
8	90	10	100.708.00	39,70
10	90	10	100.710.00	39,70
12	90	10	100.712.00	39,70
14	90	10	100.714.00	39,70
15	90	10	100.715.00	39,70
16	90	10	100.716.00	39,70
18	90	10	100.718.00	39,70
20	90	10	100.720.00	39,70
22	90	10	100.722.00	39,70
23	90	10	100.723.00	41,00
24	90	10	100.724.00	42,35
25	90	10	100.725.00	37,05
26	90	10	100.726.00	43,20
28	90	10	100.728.00	43,20
30	90	10	100.730.00	41,85
32	90	10	100.732.00	44,50
34	90	10	100.734.00	44,50
35	90	8	108.735.00	47,65
35	90	10	100.735.00	44,50
36	90	10	100.736.00	45,95
38	90	10	100.738.00	47,25
40	90	10	100.740.00	47,25
45	90	10	100.745.00	60,15
50	90	10	100.750.00	70,15

TÊTES DE MÈCHE À FAÇONNER AU CARBURE À FOND PLAT

• TCT THREADED FORSTNER BIT HEAD

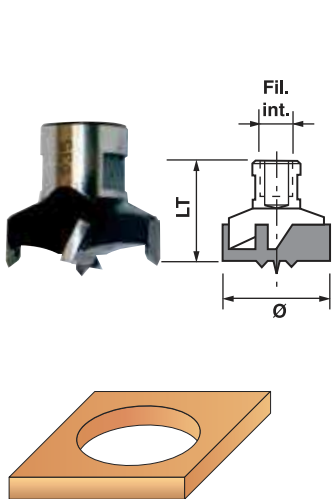

Tête de mèche à façonner avec filetage intérieur pour montage de la queue vissée (ci-dessous).

Pointe de centrage, 2 coupes dégageuses, 2 traçoirs.

TCT threaded forstner bit head with central point and 2 spurs, clockwise only.

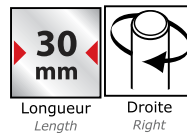

Ø	LT	Filetage	Code	Prix HT €
20	30	M12	101.720.00	46,20
25	30	M12	101.725.00	51,00
30	30	M12	101.730.00	56,15
35	30	M12	101.735.00	59,50
40	30	M12	101.740.00	75,65
45	30	M12	101.745.00	95,10
50	30	M12	101.750.00	103,15
55	30	M12	101.755.00	114,75
60	30	M12	101.760.00	153,65
65	30	M12	101.765.00	173,10
70	30	M12	101.770.00	194,85
80	30	M16	101.780.00	231,55

MANDRINS FILETÉS (POUR MONTAGE SUR TÊTE À FAÇONNER CAT. 101)

• THREADED SHANK FOR FORSTNER BIT HEAD

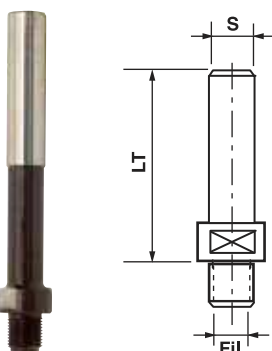

S	LT	Filetage	Code	Prix HT €
8	50	M12	890.006.01	14,80
10	50	M12	890.006.02	14,80
10	100	M12	890.006.03	18,90
12	50	M12	890.006.04	14,80
13	100	M12	890.006.06	18,90
16	100	M12	890.006.08	18,90
16	100	M16	890.006.10	40,55